

INTERNATIONAL STANDARD

ISO
7146-1

First edition
2008-10-15

Plain bearings — Appearance and characterization of damage to metallic hydrodynamic bearings —

Part 1: General

*Paliers lisses — Aspect et caractérisation de l'endommagement des
paliers métalliques à couche lubrifiante fluide —*

Partie 1: Généralités



Reference number
ISO 7146-1:2008(E)

© ISO 2008

Contents

Page

Foreword	iv
Introduction	v
1 Scope	1
2 Normative references	1
3 Terms and definitions	1
4 Descriptions, causes, and features of damage	2
4.1 Damage.....	2
4.2 Damage causes.....	2
4.3 Damage appearances.....	2
4.4 Damage characterization.....	3
4.5 Relationship between damage appearance and damage characterizations.....	3
5 Guidelines for damage analysis	5
5.1 General.....	6
5.2 Step 1.....	6
5.3 Step 2.....	6
5.4 Step 3.....	6
5.5 Step 4.....	6
5.6 Step 5.....	6
6 Damage to the bearing surface — damage characteristics, typical damage appearances and possible damage causes	7
6.1 General.....	7
6.2 Static overload.....	7
6.3 Dynamic overload.....	8
6.4 Wear by friction.....	15
6.5 Overheating.....	18
6.6 Insufficient lubrication (starvation).....	20
6.7 Contamination.....	25
6.8 Cavitation erosion.....	36
6.9 Electro-erosion.....	38
6.10 Hydrogen diffusion.....	39
6.11 Bond failure.....	41
7 Damage to the bearing back	42
7.1 General.....	42
7.2 Dynamic overload on the bearing back.....	42
7.3 Wear by friction on the bearing back.....	44
7.4 Contamination with particles on the bearing back.....	46
8 Special position of damage appearances	47
Annex A (informative) Example of use of Table 1	50

Foreword

ISO (the International Organization for Standardization) is a worldwide federation of national standards bodies (ISO member bodies). The work of preparing International Standards is normally carried out through ISO technical committees. Each member body interested in a subject for which a technical committee has been established has the right to be represented on that committee. International organizations, governmental and non-governmental, in liaison with ISO, also take part in the work. ISO collaborates closely with the International Electrotechnical Commission (IEC) on all matters of electrotechnical standardization.

International Standards are drafted in accordance with the rules given in the ISO/IEC Directives, Part 2.

The main task of technical committees is to prepare International Standards. Draft International Standards adopted by the technical committees are circulated to the member bodies for voting. Publication as an International Standard requires approval by at least 75 % of the member bodies casting a vote.

Attention is drawn to the possibility that some of the elements of this document may be the subject of patent rights. ISO shall not be held responsible for identifying any or all such patent rights.

ISO 7146-1 was prepared by Technical Committee ISO/TC 123, *Plain bearings*, Subcommittee SC 2, *Materials and lubricants, their properties, characteristics, test methods and testing conditions*.

This first edition of ISO 7146-1, together with ISO 7146-2, cancels and replaces ISO 7146:1993 the technical content of which has been technically revised and augmented.

ISO 7146 consists of the following parts, under the general title *Plain bearings — Appearance and characterization of damage to metallic hydrodynamic bearings*:

- *Part 1: General*
- *Part 2: Cavitation erosion and its countermeasures*

Introduction

In practice, damage to a bearing may often be the result of several mechanisms operating simultaneously. It is the complex combination of design, manufacture, assembly, operation, maintenance, and possible reconditioning which often causes difficulty in establishing the primary cause of damage.

In the event of extensive damage or destruction of the bearing, the evidence is likely to be lost, and it will then be impossible to identify how the damage came about.

In all cases, knowledge of the actual operating conditions of the assembly and the maintenance history is of the utmost importance.

The classification of bearing damage established in this part of ISO 7146 is based primarily upon the features visible on the running surfaces and elsewhere, and consideration of each aspect is required for reliable determination of the cause of bearing damage.

Since more than one process may cause similar effects on the running surface, a description of appearance alone is occasionally inadequate in determining the cause of damage. Thus Clause 4 is subdivided into several subclauses including damage appearance and damage characteristics.

For the procedure of damage analysis, Clause 5 may give a helpful guide.

In Clauses 6 and 7, examples of all damage characteristics with typically associated damage appearance are given.

Plain bearings — Appearance and characterization of damage to metallic hydrodynamic bearings —

Part 1: General

1 Scope

This part of ISO 7146 defines, describes and classifies the characteristics of damage occurring in service to hydrodynamically lubricated metallic plain bearings and journals. It assists in the understanding of the various characteristic forms of damage which may occur.

Consideration is restricted to damage characteristics which have a well-defined appearance and which can be attributed to particular damage causes with a high degree of certainty. Various appearances are illustrated with photographs and diagrams.

2 Normative references

The following referenced documents are indispensable for the application of this document. For dated references, only the edition cited applies. For undated references, the latest edition of the referenced document (including any amendments) applies.

ISO 4378-1, *Plain bearings — Terms, definitions, classification and symbols — Part 1: Design, bearing materials and their properties*

ISO 4378-2, *Plain bearings — Terms, definitions, classification and symbols — Part 2: Friction and wear*

ISO 4378-3, *Plain bearings — Terms, definitions, classification and symbols — Part 3: Lubrication*

ISO 4378-4, *Plain bearings — Terms, definitions, classification and symbols — Part 4: Basic symbols*

ISO 7146-2, *Plain bearings — Appearance and characterization of damage to metallic hydrodynamic bearings — Part 2: Cavitation erosion and its countermeasures*

3 Terms and definitions

For the purposes of this document, the terms and definitions given in ISO 4378-1, ISO 4378-2, ISO 4378-3, ISO 4378-4 and the following apply.

3.1

damage to plain bearings

bearing damage

all changes in appearance occurring on the bearing surface and/or on the bearing back during operation that adversely affect the performance of the bearing

4 Descriptions, causes, and features of damage

4.1 Damage

4.1.1 General

Damage to plain bearings is a phenomenon that adversely changes their tribological function, usually accompanied with a change in appearance. The damage is initiated by the damage cause and develops to the end of service life.

As long as no abnormal conditions occur, service life of the plain bearing relates to the service life of the machine.

4.1.2 Indicators of damage

Typical indicators observed during machine operation are: continuously increasing service temperature, decline of lubricant pressure, noise, vibration, and bad smell.

4.2 Damage causes

The cause is the practical event that initiates and leads to damage. The majority of damage causes will be found outside the bearing.

4.3 Damage appearances

Damage appearance is a defined visible picture of the bearing surface and/or of the bearing back. Damage appearances are clearly different from each other.

A plain bearing failure can show various damage appearances. Usually damage appearances are directly associated with damage characteristics, but not directly with the damage cause (for exceptions, see 6.8 and 6.9).

List of damage appearances:

- a) depositions;
- b) creep deformation;
- c) deformation due to temperature cycles;
- d) thermal cracks;
- e) fatigue cracks;
- f) material relief (loss of bond);
- g) frictional corrosion;
- h) melting out, seizure;
- i) polishing, scoring;
- j) traces of mixed lubrication, worn material;
- k) blue, black colour;
- l) corrosion, fluid erosion;
- m) embedded particles, particle-migration tracks, formation of wire wool;
- n) electric arc craters;
- o) cavitation erosion appearance: worn-out material.

4.4 Damage characterization

4.4.1 General. A damage characterization is a description of what has happened based on a detected typical combination of damage appearances. Defined characteristics provide the basis for establishing the cause of damage.

Damage characterizations are clearly different from each other, as specified in 4.4.2 to 4.4.11.

4.4.2 Static overload: material is loaded above compressive yield strength corresponding to actual operation temperature.

4.4.3 Dynamic overload: material is loaded above fatigue strength corresponding to actual operation temperature. Intensive dynamic load also favours damage by weakening the fit.

4.4.4 Wear by friction: wear by friction is confined to changes in microgeometry and to the loss of material as a result of interaction between journal and bearing. Movement between backing and housing also favours wear by friction.

4.4.5 Overheating: the heat balance in the lubricant, the bearing, the environment, and the cooling system as required at design stage is not realized resulting in a higher temperature than anticipated. The viscosity and, therefore, the load capacity decrease with increasing temperature. This results again in temperature increase. The bearing, therefore, cannot operate stably if cooling cannot stop further temperature increase.

4.4.6 Insufficient lubrication (starvation): affecting the tribological system.

4.4.7 Contamination of lubricant with foreign particles or reaction products can result in damage to a bearing. Foreign particles embedded between bearing backing and housing also favour damage.

4.4.8 Cavitation erosion: decreased pressure in liquids leads to evaporation of liquids and formation of vapour bubbles, which, when liquid pressure increases, implode, generating locally very high pressure, and cause erosion on sliding surfaces.

4.4.9 Electroerosion: a potential difference between journal and bearing can lead to an electric arc with locally high current flow which damages journal and bearing surface.

4.4.10 Hydrogen diffusion: hydrogen may be incorporated in the steel backing or in an electroplated layer of the bearing. If hydrogen diffusion is blocked by a layer, blisters will occur.

4.4.11 Bond failure: delamination between lining and backing or between layers. A metallographic examination is required to distinguish from other damage characterizations.

4.5 Relationship between damage appearance and damage characterizations

Damage characterization and damage appearance alter with the progress of damage from a primary to a secondary characteristic (see Figure 1).

Different damage characterizations can correspond to the same damage appearance.

One damage characterization can correspond to various damage appearances.

Multiple damage characteristics can be found in one failure event.

The damage characteristics provide the basis for analysing the cause (see Figure 2).

Typical relationships are shown in Table 1 for damage to sliding surface and to bearing back. In most cases, Table 1 is the guideline for diagnosis of the final damage cause from the damage appearances via the damage characteristics.

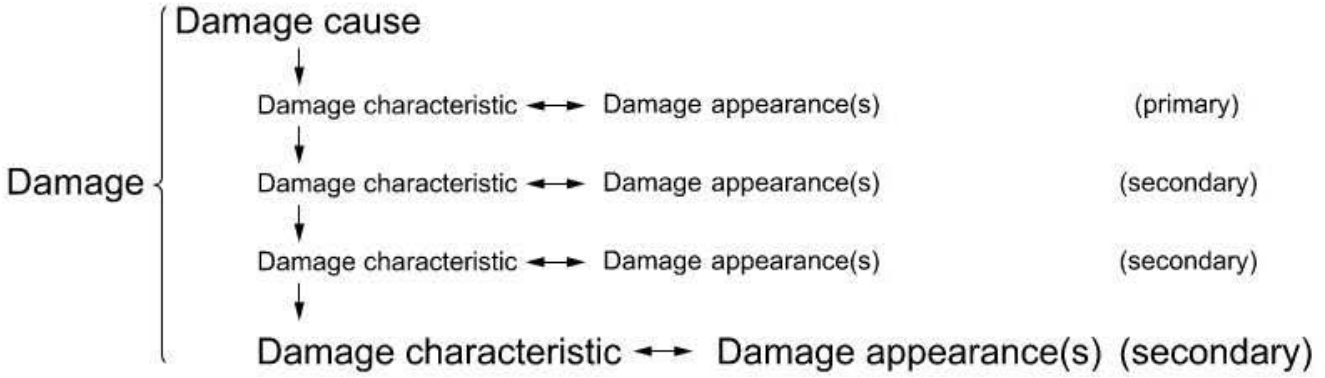
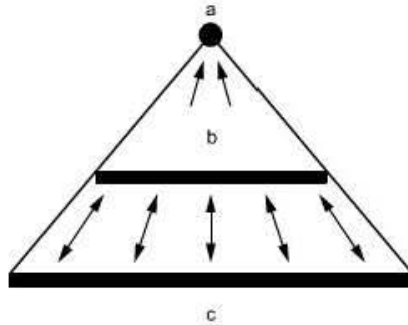


Figure 1 — Damage appearances alter with the progress from primary to secondary characteristics



- a Damage cause.
- b Damage characteristics.
- c Damage appearances.

Figure 2 — Damage characteristics provide the basis for analysing the cause

5 Guidelines for damage analysis

Table 1 — Interaction of damage appearances and damage characterizations

Damage appearance														Damage characterizations	Subclause		
Depositions	Creep deformation	Deformations due to temperature cycles	Thermal cracks	Fatigue cracks	Material relief (loss of bond)	Frictional corrosion	Melting out, scoring	Polishing, scoring	Trace of mixed lubrication, worn material	Blue, black colour	Corrosion	Fluid erosion	Embedded particles, particle-migration tracks, formation of wire wool	Electric arc craters	Cavitation erosion appearance: material worn out		
x	x		x						x							Static overload	6.2
				x	x											Dynamic overload ^a	6.3
				x		x										Dynamic overload ^b	7.2
								x	x							Wear by friction ^a	6.4
								x								Wear by friction ^b	7.3
x	x	x	x						x							Overheating	6.5
							x		x	x						Insufficient lubrication (starvation)	6.6
x								x	x		x	x	x			Contamination (particles, chemicals) ^a	6.7
x								x	x		x		x			Contamination (particles, chemicals) ^b	7.4
															x	Cavitation erosion	6.8 and ISO 7146-2
														x		Electro-erosion	6.9
					x											Hydrogen diffusion	6.10
					x											Bond failure	6.11
^a Damage to the sliding surface. ^b Damage to the bearing back.																	

5.1 General

Analysis should be undertaken only by experts experienced in bearing metallurgy, bearing technology and bearing damage. Damage analyses based on photos alone are mostly unsuccessful.

The following steps are a guideline for damage analysis.

5.2 Step 1

Establish service life. There is significant difference between damage after a short service life and damage after a long service life. With both cases similar damage appearances occur, but the cause is usually different.

Typical causes of damage after short service life: faults in geometry or assembling, dirt, effect from a previous damage, modified service conditions since last start up.

Typical cause of damage after long service life: modified service conditions.

Typical cause of damage after very long service life: reduced dynamic material capability due to fatigue.

5.3 Step 2

Strict differentiation between damage characterization and damage appearance is important. For a thorough analysis, all visible damage appearances shall be evaluated and combined in one or more damage characterizations, based on Table 1.

5.4 Step 3

Take into consideration the total system: bearing — shaft — lubricant — housing.

It is helpful to make a chemical analysis of a sample from the bearing layer and to check its microstructure. If necessary, lubricant and filter content should be analysed.

5.5 Step 4

All information in connection with the period before the detected damage and the period during the damage should be brought together.

5.6 Step 5

Reviewing the initial list of damage characteristics together with the information from steps 3 and 4 usually leads to a reduction of the number of damage characteristics under consideration. This will lead to the possible damage cause.

See Annex A for an example of use of Table 1.

6 Damage to the bearing surface — damage characteristics, typical damage appearances and possible damage causes

6.1 General

A discussion of damage to the bearing surface follows. For each damage characterization given in 4.4, typical damage appearances, possible damage causes and typical examples are given.

6.2 Static overload

6.2.1 Typical damage appearances

Creep deformation: shallow depressions of bearing material in the region of maximum load and temperature, beginning smooth and ending in crack-free semicircular bulges in the direction of rotation, sometimes like crests of waves (see Figure 3).

Traces of mixed lubrication (see Figure 4), depositions, thermal cracks.

6.2.2 Possible damage causes

Loading of the bearing was higher than that allowed for in the design and/or the bearing temperature was higher than estimated for an extended period.

6.2.3 Typical examples (see Figures 3 and 4)



Figure 3 — Creep deformation, shown by crack-free semicircular bulges in the direction of rotation (material: steel/tin-based white metal)



Figure 4 — Propeller shaft bearing, showing the effects of too slow a speed in relation to load capacity (material: steel/tin-based white metal)

6.3 Dynamic overload

6.3.1 Typical damage appearances

Fatigue cracks: Cracks which extend from the sliding surface in the loaded zone propagating as a network. The cracks change direction above the bonding area.

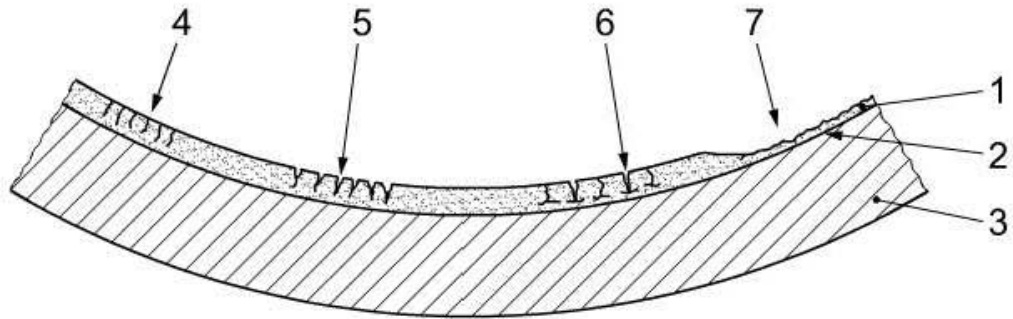
Lining material from the backing is the final result of the development of fatigue cracks (see Figure 5).

See also possible damage appearances such as frictional corrosion on the bearing back (7.1).

6.3.2 Possible damage causes

The cracks start when the fatigue limit of the bearing material is exceeded due to high dynamic load at the operating temperature. The damage is not based on bond faults.

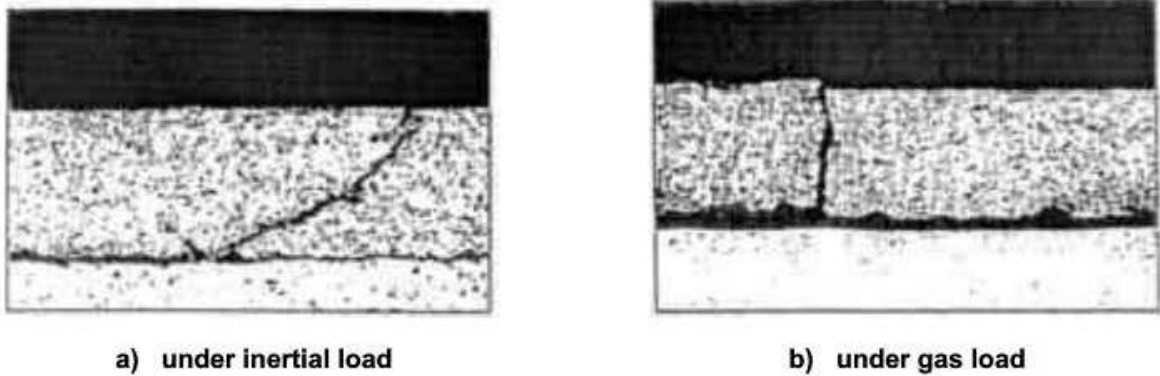
6.3.3 Typical examples (see Figures 5 to 12)



Key

- | | |
|--------------------|---|
| 1 lining material | 5 eroded cracks |
| 2 bonding area | 6 cracks with perpendicular propagation |
| 3 backing material | 7 material relief |
| 4 cracks | |

Figure 5 — Schematic diagram of progress of fatigue cracks



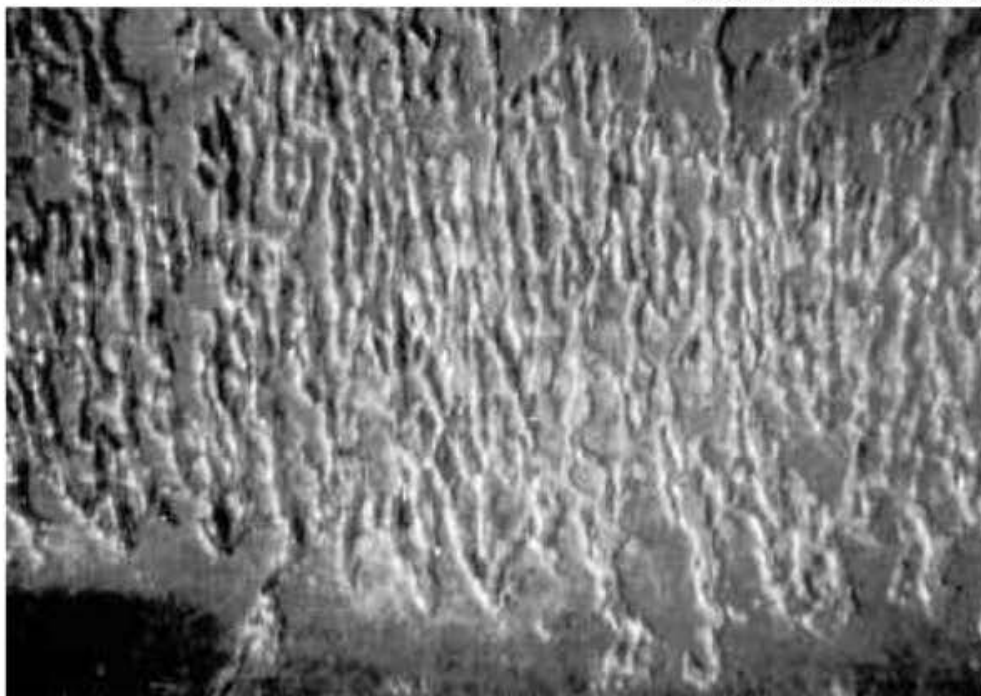
**Figure 6 — Typical fatigue cracks of internal combustion engine bearing
(material: steel/aluminium alloy)**

direction of shaft rotation →



a)

direction of shaft rotation →

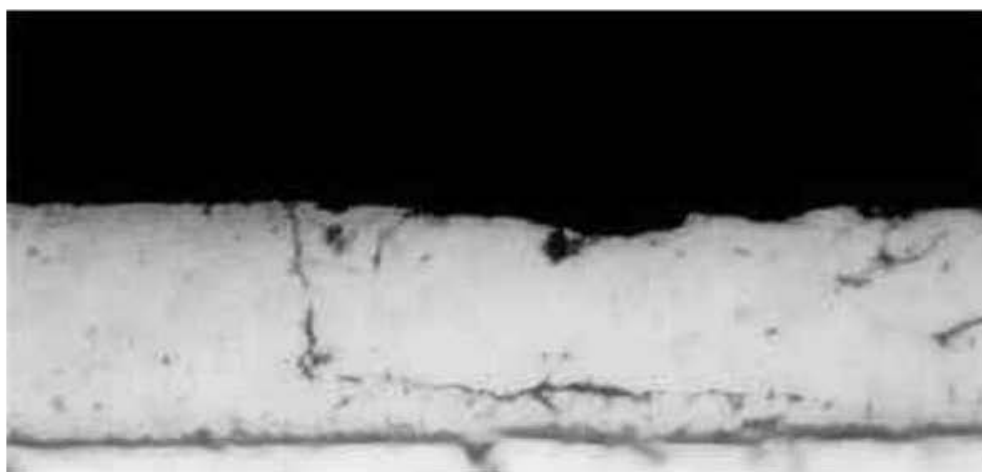


b) section from Figure 7 a) showing the lower half at increased magnification

Figure 7 — Cracks in the electroplated overlay (material: steel/lead bronze/electroplated overlay)

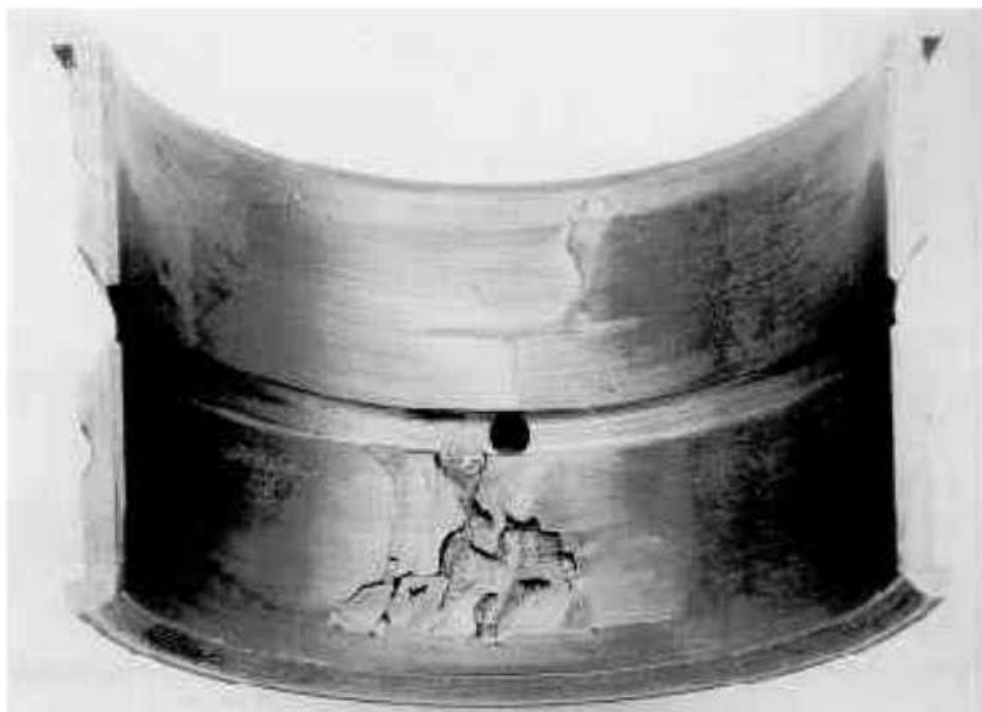


Figure 8 — Cracks in the overlay of a multilayer bearing in a narrow area of high loading (material: steel/lead bronze/electroplated overlay)



NOTE The crack runs at a small distance from the bonding area.

Figure 9 — Section of spalled layer (material: steel/tin-based white metal)



a)

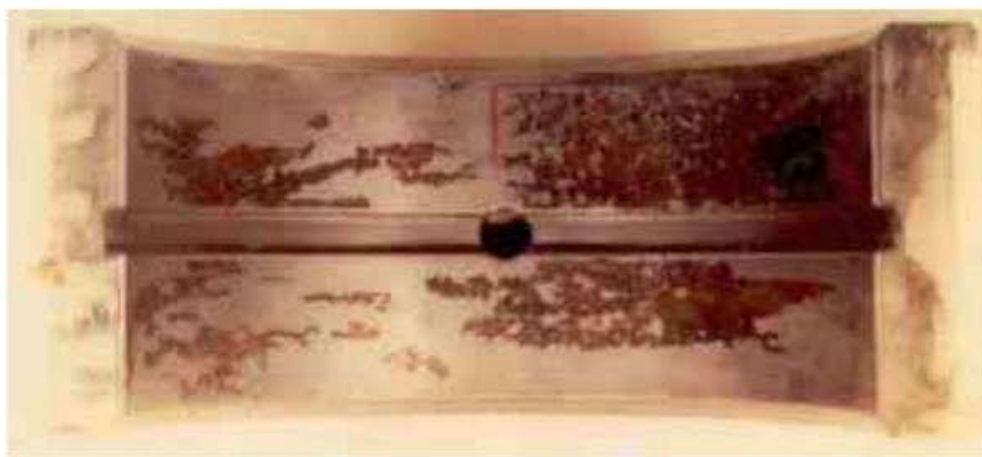


b)

**Figure 10 — Fatigue cracks and material relief by dynamic overload
(material: steel/tin-based white metal)**



**Figure 11 — Material relief by dynamic overload because of insufficient fit on the bearing back
(see also 7.2)**



a)



b) section from Figure 12 a): clear illustration of the defect at increased magnification

Figure 12 — Detachment of the overlay leaving occasional residual islands relieved by a dark background (material: steel/lead bronze/electroplated overlay)

6.4 Wear by friction

6.4.1 Typical damage appearances

Polishing happens during a short period of mixed lubrication on start and stop conditions. As long as this polishing does not give rise to a detectable reduction in wall thickness, such running-in marks are normal. This is not damage in the sense of the definitions of this part of ISO 7146 (see Figure 13).

Scoring occurs under continuous or recurrent mixed-film lubrication conditions for longer periods. Scoring marks appear in the most highly loaded region of the bearing, across the whole width of the bearing. The transition from unmarked to marked areas is quite gradual. The reduction in wall thickness is significant.

Segmented plain bearings experiencing appreciable wear at high rubbing surface temperatures often initially show traces of mixed lubrication; later, worn material from one segment is deposited on the leading edge of the next segment in the direction of rotation (see Figure 16).

For information on possible damage appearance on the bearing back, see 7.3.

6.4.2 Possible damage causes

Extreme operating conditions such as slow turning or starting under load, short and hard contact with the counterface, inadequate clearance or other geometrical defects (misalignment or faulty mounting) lead to wear by friction.

6.4.3 Typical examples (see Figures 13 to 17)

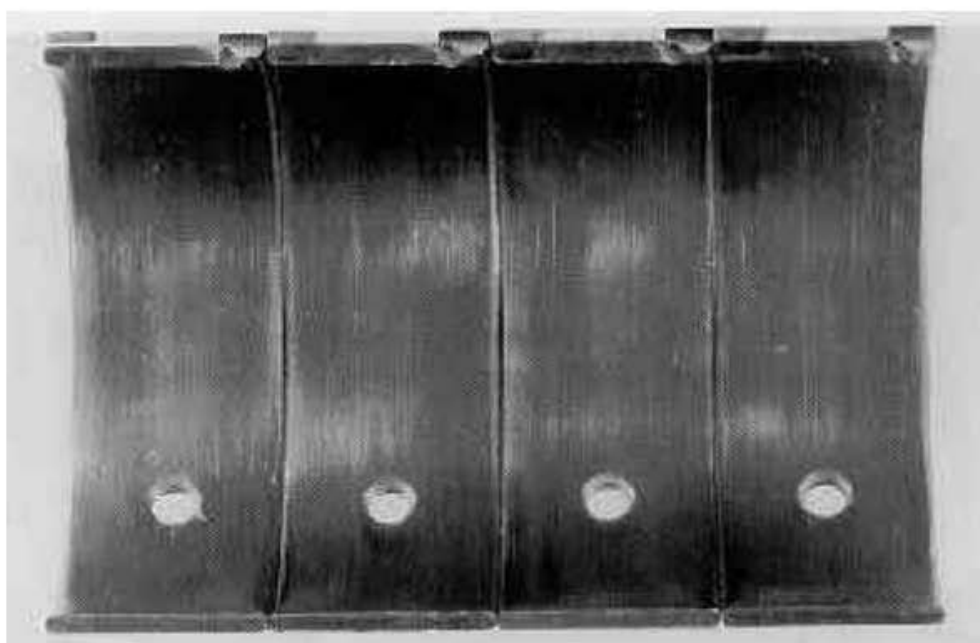


Figure 13 — Running-in polishing and burnishing in the main loaded area of a thin-walled bearing (material: steel/AlSn)

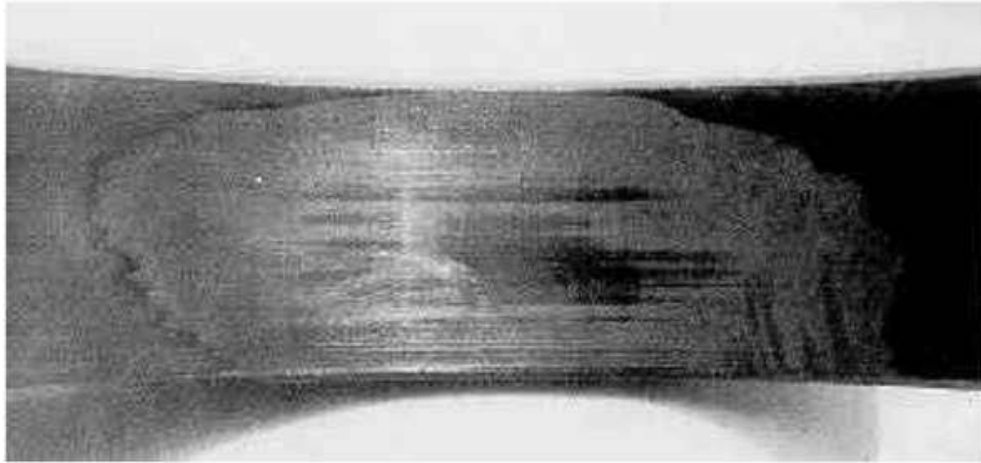


Figure 14 — Abrasive wear of the overlay in the main loaded area on a thin-walled bearing (material: steel/lead bronze/electroplated overlay)

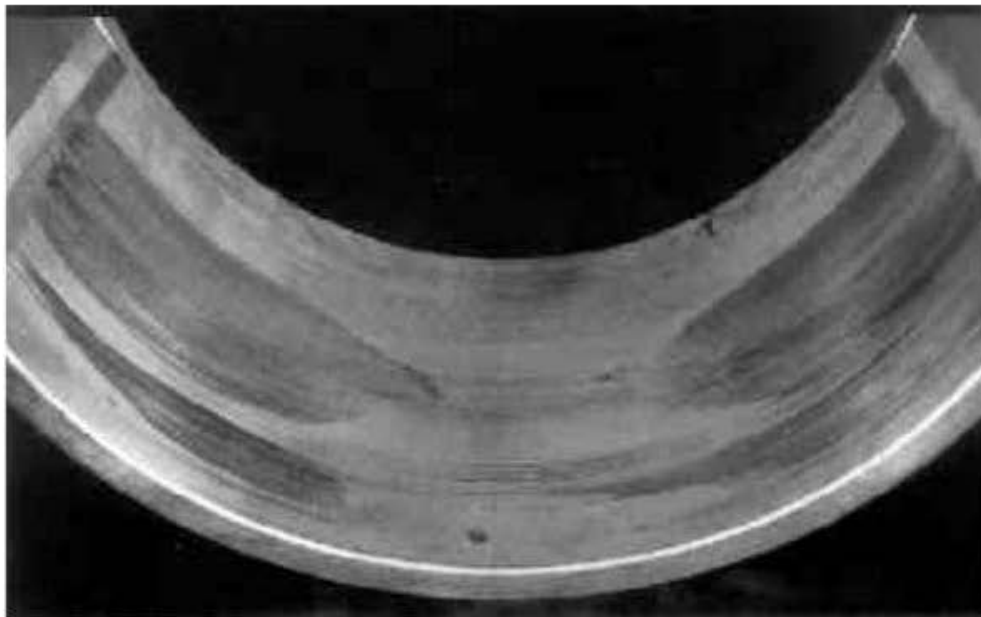


Figure 15 — Abrasive wear near the ends of the bearing (joint face area) in a thick-walled journal bearing, due to faulty mounting (material: steel/tin-based white metal)

direction of shaft rotation →



Figure 16 — Wear by friction due to segment assembling on different levels — worn material from one segment deposited on the leading edge of the next segment in the direction of rotation — the segment shown gets a reduction in oil supply (secondary damage characteristic: loss of lubricant) (material: steel/tin-based white metal)



Figure 17 — Wear by misalignment between bearing backing and shaft (material: steel/tin-based white metal)

6.5 Overheating

6.5.1 Typical damage appearances

Deposition: overheating leads to ageing of the lubricant, its thermal decomposition, and finally to depositions. The phenomenon is concentrated in the minimum oil film region, or in other places in the oil circulatory system, occurring more severely when oil additives have become depleted (see Figure 19).

Brown or black deposits appear on the bearing surface, but not as a result of chemical attack between the bearing material and the lubricant. The discoloration is due to very thin lacquer-like oxidized layers in areas of maximum temperature. It is relatively soft and can generally be removed using a solvent cleaning fluid or scratched off using a pointed instrument (see Figure 20).

Creep deformation: shallow depressions of bearing material in the region of maximum load and temperature, initially smooth and ending in crack-free semicircular bulges in the direction of rotation, sometimes like crests of wave (see Figure 18).

Deformations due to temperature changes: as tin crystals have anisotropic thermal expansion along the different crystal axes, an extended period of excessive start-up cycles may cause thermal ratcheting between crystals (in extreme cases, this may lead to intercrystalline cracking).

Thermal cracks have an irregular unsystematic orientation characteristic. These typical appearances can be characterized as creep deformation, traces of mixed lubrication and worn material (see Figure 21).

6.5.2 Possible damage causes

Failure of heat flow, resulting in overheating.

Defects in oil cooling, increased surrounding temperature, hot oil carry-over.

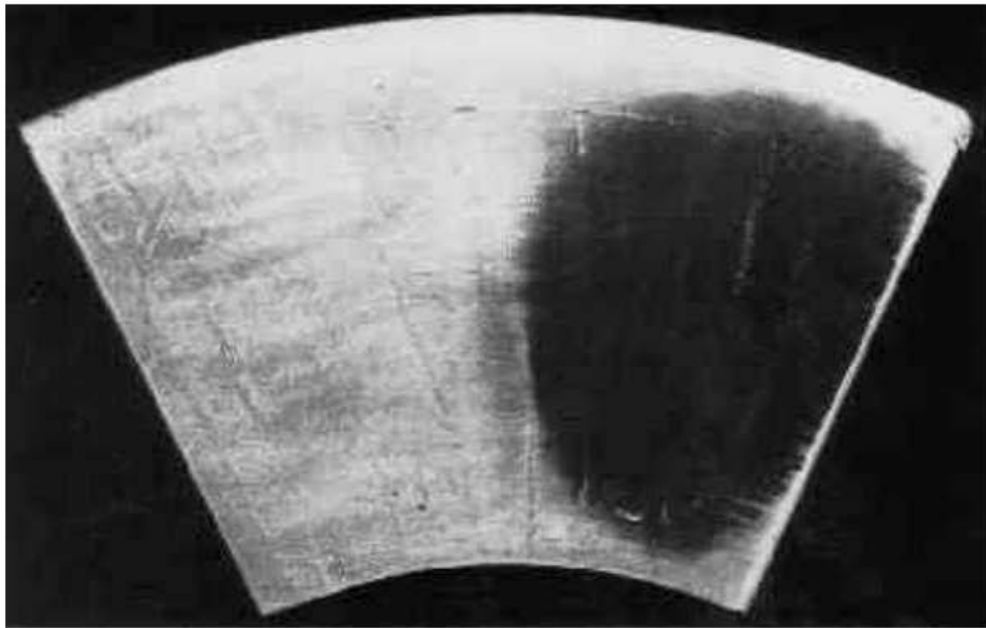
Reduced melting point due to alloy impurities will favour thermal cracks.

6.5.3 Typical examples (see Figures 18 to 21)

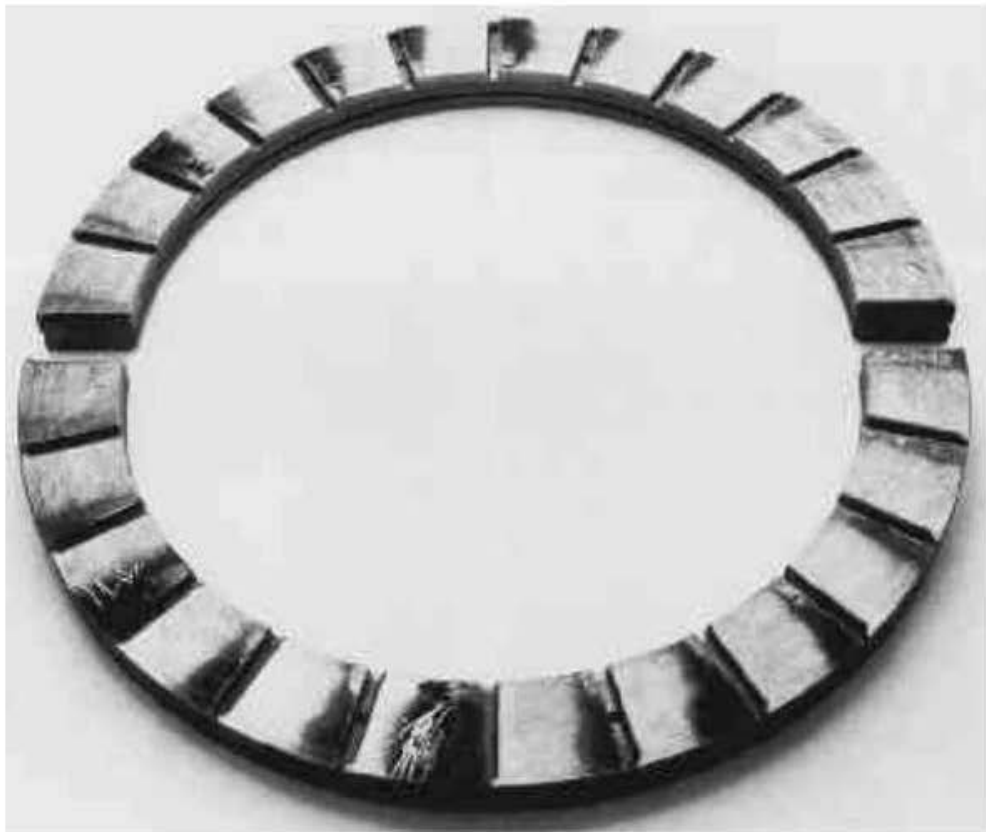


Figure 18 — Creep deformation due to overheating with formation of black depositions (material: steel/tin-based white metal)

direction of shaft rotation →



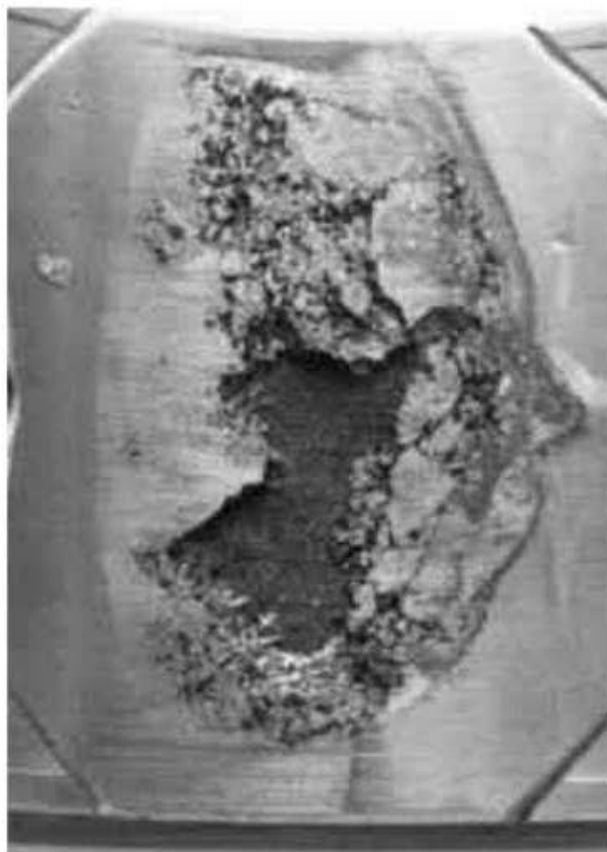
**Figure 19 — Thrust bearing tilting pad with deposits of oil carbon
(material: steel/tin-based white metal)**



NOTE The black/brown deposit is easily removed using the thumbnail (see lowest segment).

Figure 20 — Deposit of oil carbon on a thrust bearing ring (material: steel/tin-based white metal)

direction of shaft rotation →



**Figure 21 — Radial segments with thermal cracks and worn material
 (material: steel/tin-based white metal)**

6.6 Insufficient lubrication (starvation)

6.6.1 Typical damage appearances

Blue, black colour on the bearing, shaft, housing.

Traces of mixed lubrication, worn material.

Melting out, seizure (adhesive wear).

6.6.2 Possible damage causes

Insufficient lubricant supply.

Reduction of lubricant supply due to geometric deviations (e.g. missing wedge gap or missing bearing clearance).

Most damage in a late secondary stage will end with loss of lubrication.

6.6.3 Typical examples (see Figures 22 to 27)

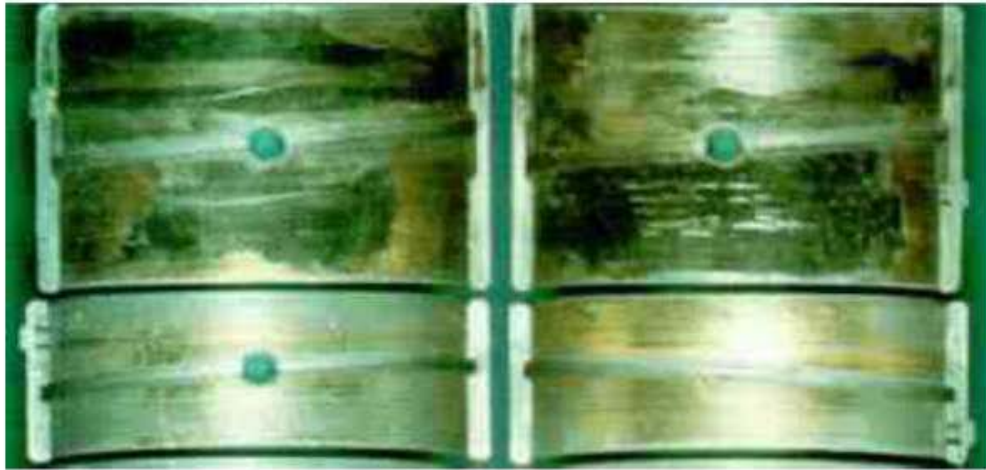


Figure 22 — Seizure on a multilayer plain bearing with totally detached intermediate layer, accompanied by melting, metal wear and severe scoring (material: steel/lead bronze/electroplated overlay)

← direction of shaft rotation

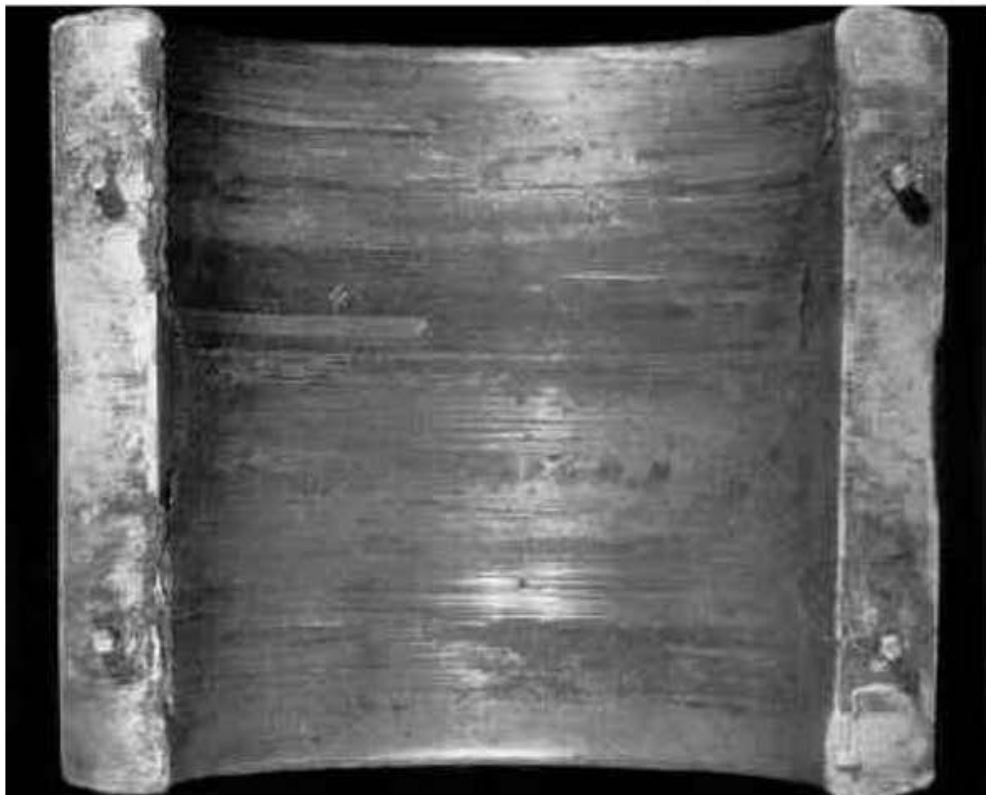
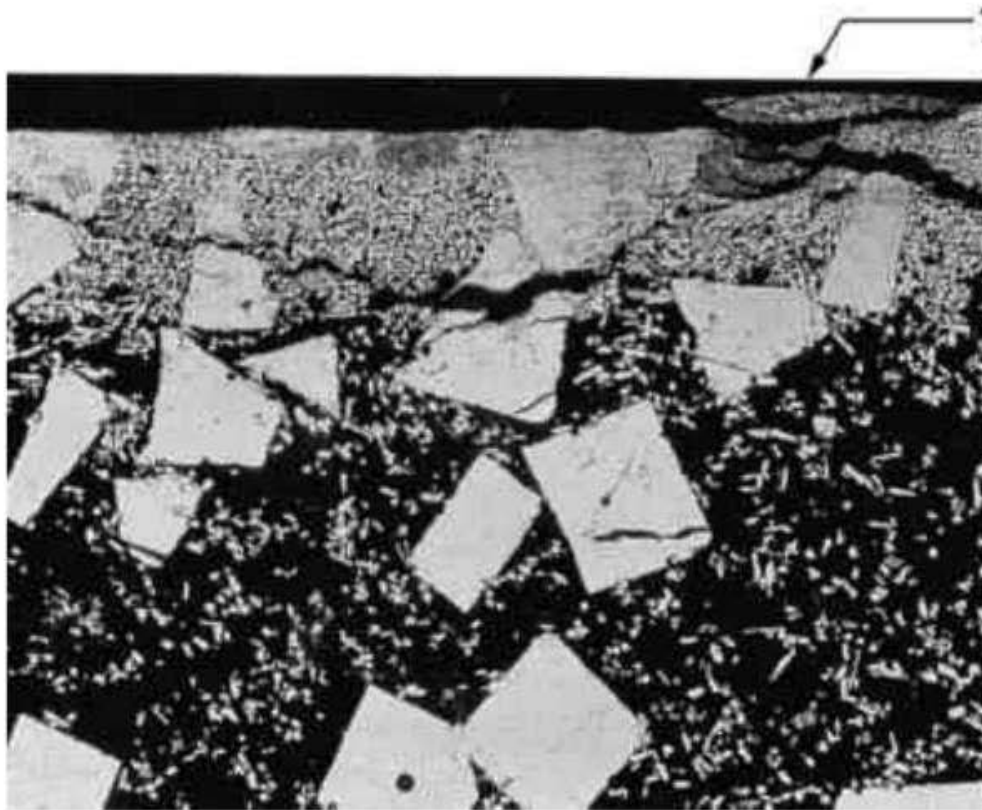


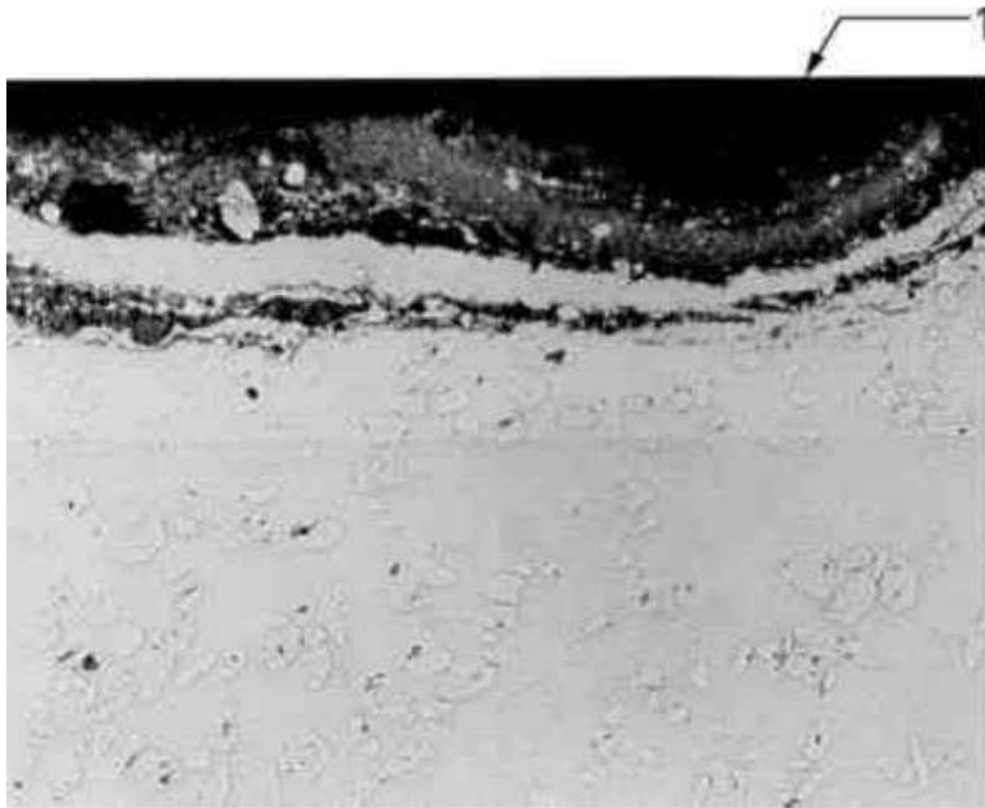
Figure 23 — Destruction of bearing metal due to loss of lubricant in a thick-walled bearing (material: steel/tin-based white metal)



Key

- 1 sliding surface

Figure 24 — Bearing metal molten along the surface due to overheating and loss of lubricant, followed by cracking of the (etched) bearing metal (material: steel/tin-based white metal)



Key

1 sliding surface

Figure 25 — Bearing metal layer exhibiting surface melting with entrained carbonaceous residue, unetched (material: steel/tin-based white metal)



Figure 26 — Melting at the bearing edge and within the groove (material: steel/lead bronze/electroplated overlay)

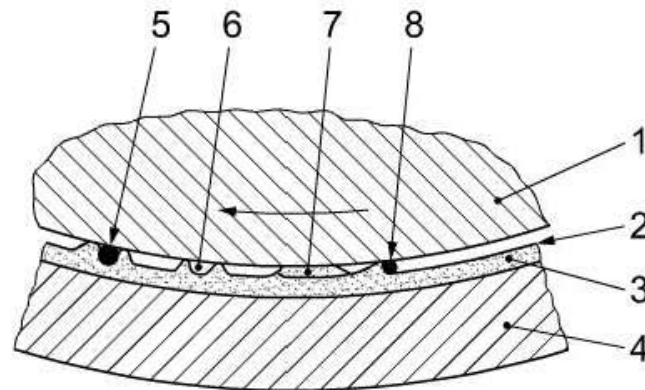


**Figure 27 — Coloured surface due to loss of lubricant, melting out, seizure
(material: steel/tin-based white metal)**

6.7 Contamination

6.7.1 Contamination with particles

See Figure 28.



Key

- | | |
|--------------------|---|
| 1 journal | 5 embedded particle usually with a highly reflective raised ring (halo) of bearing material around it (see also Figure 29) |
| 2 lubricant | 6 craters or scratches left by displaced particles (see also Figures 30 and 32) |
| 3 lining material | 7 particle of bearing metal from a damage site elsewhere in the bearing smeared onto the bearing surface (see also Figure 29) |
| 4 backing material | 8 particle with entry track |

Figure 28 — Schematic diagram of possible embeddings

6.7.1.1 Typical damage appearances

Embedded particles.

Scoring (see Figure 31)

Particle-migration tracks (see Figures 29, 32, 33 and 34).

Particles embedded in the bearing surface, surrounded by raised bearing metal displaced as the particle is embedded. The raised bearing metal appears as a highly reflective halo around the embedded particle (see Figure 30). The halo comes in contact with the counterface. Traces of mixed lubrication and worn material occur.

The formation of wire wool can be caused by hard foreign particles partially embedded in the bearing surface cut into the rotating shaft thereby removing material from the shaft surface. Wire wool formed in this way can also be once more embedded in the bearing metal and usually brings about total failure very quickly (see Figure 35).

Chevron appearances are particle-migration tracks generated by hard particles. The chevrons point in a direction opposite to the direction of rotation of the journal (see Figure 36).

Foreign particles in the oil can also lead to fluid erosion.

With regard to possible damage appearances on the bearing back, see also 7.4.

6.7.1.2 Possible damage causes

Particle contamination of the oil by residues from manufacturing, assembly or commissioning (metal turnings, casting sand, paint), can result from poor maintenance or damage to the filter. Particles can be produced by wear or damage to other bearings or machine components. Damaged seals result in contamination with particles from the area surrounding the machine (e.g. cement in the cement industry).

The formation of wire wool can be expected when the shaft steel contains chromium. Hard particles embedded in the bearing surface cut into the rotating shaft thereby removing material from the shaft surface (wire wool).

Chevron appearances: The migration tracks are caused by particles originating from the surface of nitrided journals. Particles with magnetic properties spall from the journal due to insufficient grinding and removal of the white friable layer.

Fluid erosion is caused by lubricant under high shear rate with included foreign hard particles such as wear debris, dust, and combustion residue.

6.7.1.3 Typical examples (see Figures 29 to 36)

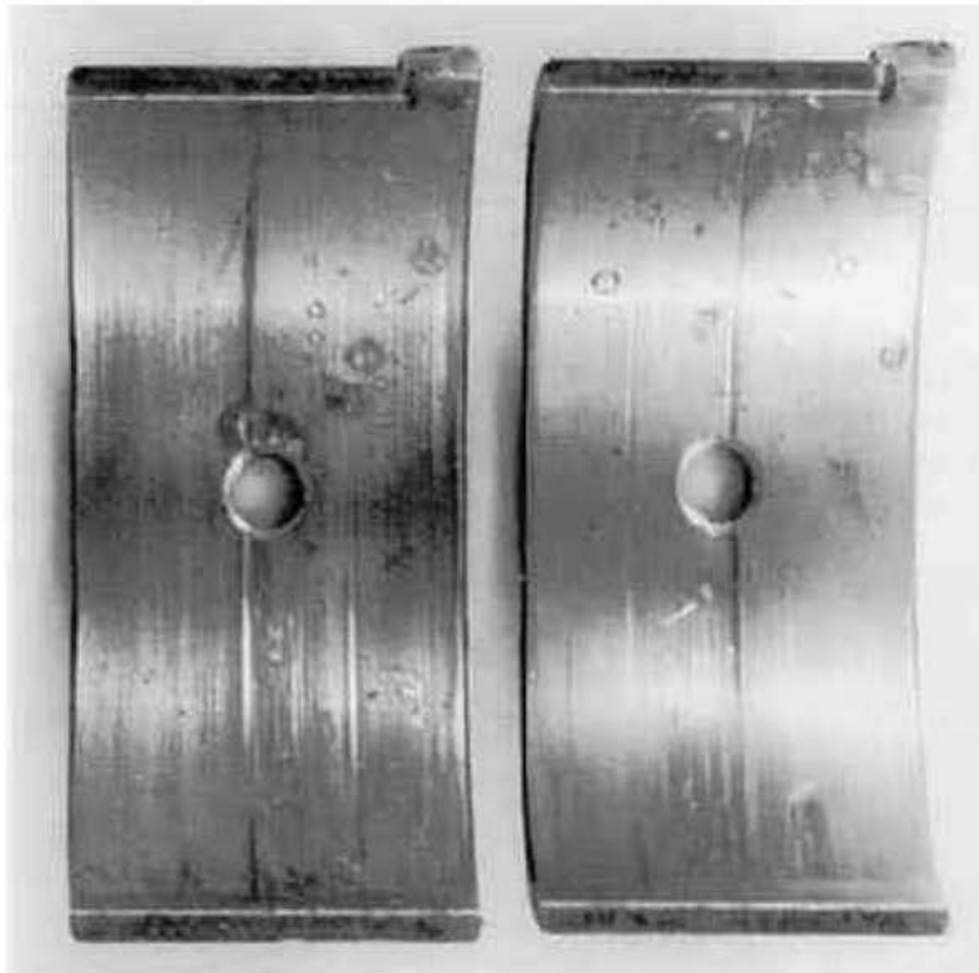
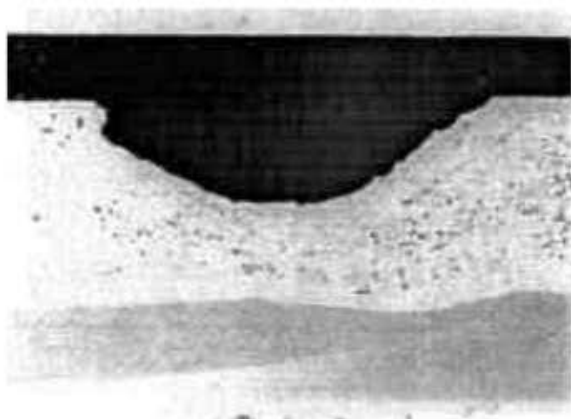


Figure 29 — Embedding of particles, characteristic of embedding, see Figure 28, and migration tracks (material: steel/AlSn)



Figure 30 — Crater left by displaced particle surrounded by reflective ring (halo), characteristic of embedding, see Figure 28, label 6, (material: steel/lead bronze/electroplated overlay)



a) deformation at the lining surface cross-section



b) (material: steel/lead bronze/electroplated overlay)

Figure 31 — Deep circumferential score with displaced bearing metal alongside



← direction of shaft rotation

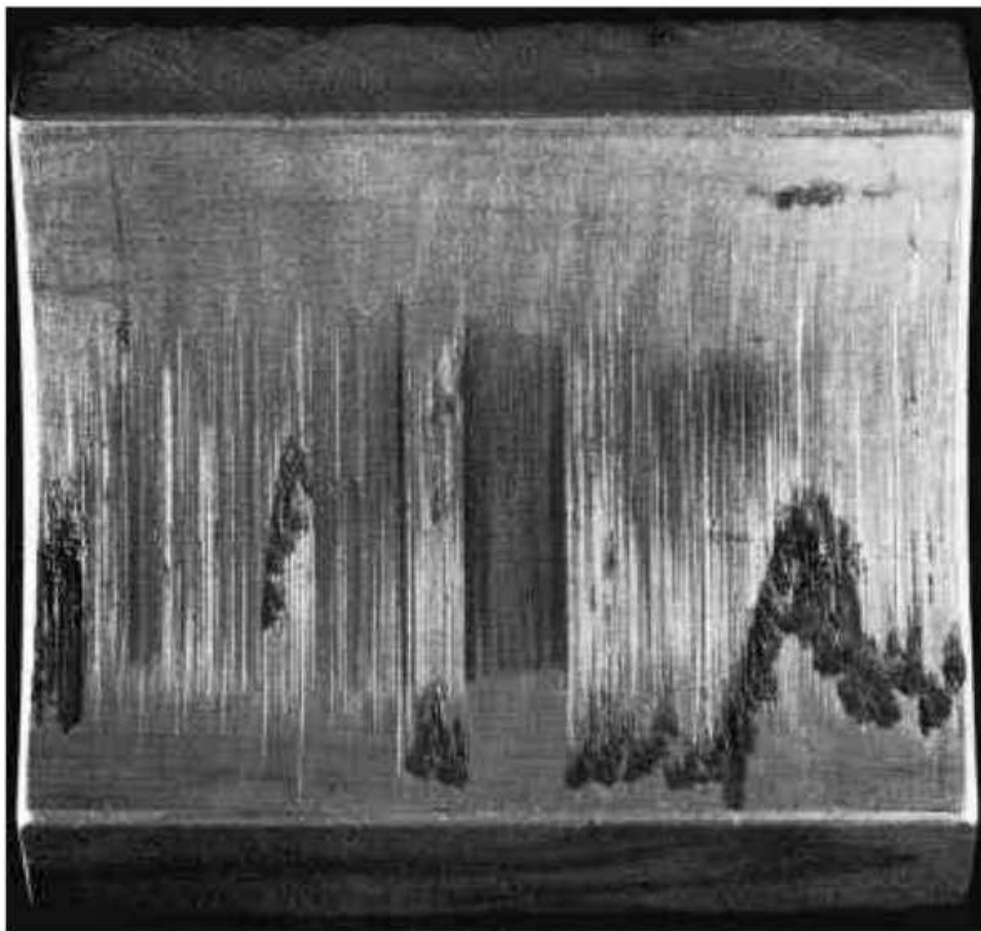
Figure 32 — Cement mill bearing with contamination by cement particles entrained by the oil as a result of damaged seals. Particle-migration tracks are visible (material: steel/tin-based white metal)



Figure 33 — Contamination by foreign particles containing Fe — particle-migration tracks are visible



Figure 34 — Particle-migration tracks concentrated to the pocket area of a thin-walled bearing (material: steel/AlSn)



a) wire wool on a journal pad (material: steel/tin-based white metal)



b) wire wool on the shaft

Figure 35 — Attack caused by abrasive and adhesive effects in the initial stage (wire wool) (material: steel)



Figure 36 — Chevron-like defect caused by particles from iron nitride compound layer of nitrided shafts (material: steel/lead bronze/electroplated overlay)

6.7.2 Contamination with chemicals

6.7.2.1 Typical damage appearance

Corrosion.

Fluid erosion.

6.7.2.2 Possible damage causes

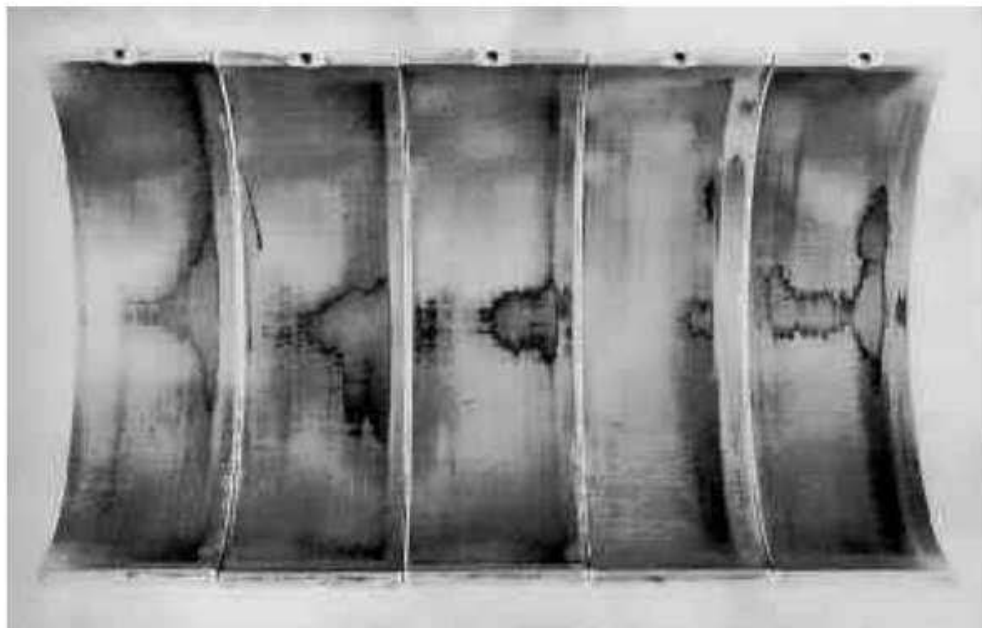
The corrosive nature of the lubricant can be present from the outset, or can develop during long periods of operation as a result of contamination by water, antifreeze or combustion residues, etc. The smallest leakages in the lubrication system can lead to chemical reaction and corrosion. Corrosion of the overlay is accelerated when the corrosion-resistant constituents are missing in the original condition or are lost from the overlay as a result of diffusion processes taking place at elevated temperatures.

Contamination of the lubricant is possible by halogenated hydrocarbons from the refrigerant or by certain other chemicals. Copper may be dissolved from the oil cooler tubes. This copper may be deposited electrolytically on metal surfaces in tribological systems. High temperatures accelerate the reaction. This can be followed by copper diffusion and accompanying corrosion.

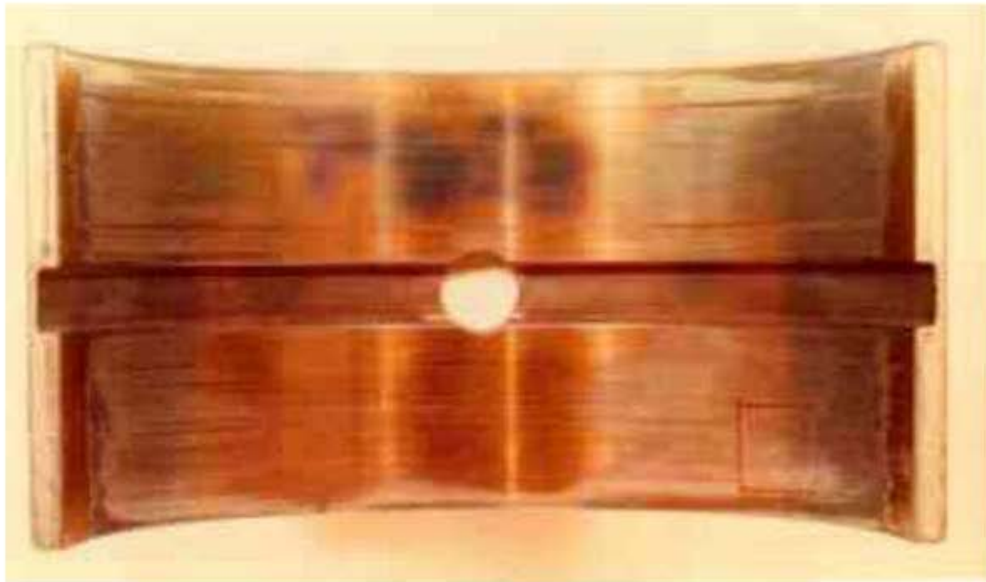
For corrosion due to water in the oil, the critical water concentration depends on oil and operating conditions, but can occur generally when water is present in excess of 1 % volume fraction.

Dissolution of bearing material by corrosion leads to fluid erosion. Removal of an anti-oxidative layer by fluid erosion may initially lead to premature corrosion, which in turns leads to fluid erosion.

6.7.2.3 Typical examples (see Figures 37 to 42)



**Figure 37 — Discoloration of the bearing surface in the main loaded zone by tribochemical reaction
(material: steel/lead bronze/electroplated overlay)**



a)



b) section from the marked area of Figure 38 a) at increased magnification

Figure 38 — Corrosive detachment of the overlay in the area of the oil hole and selective corrosive detachment on the right-hand side of the bearing lining (material: steel/lead bronze/electroplated overlay)

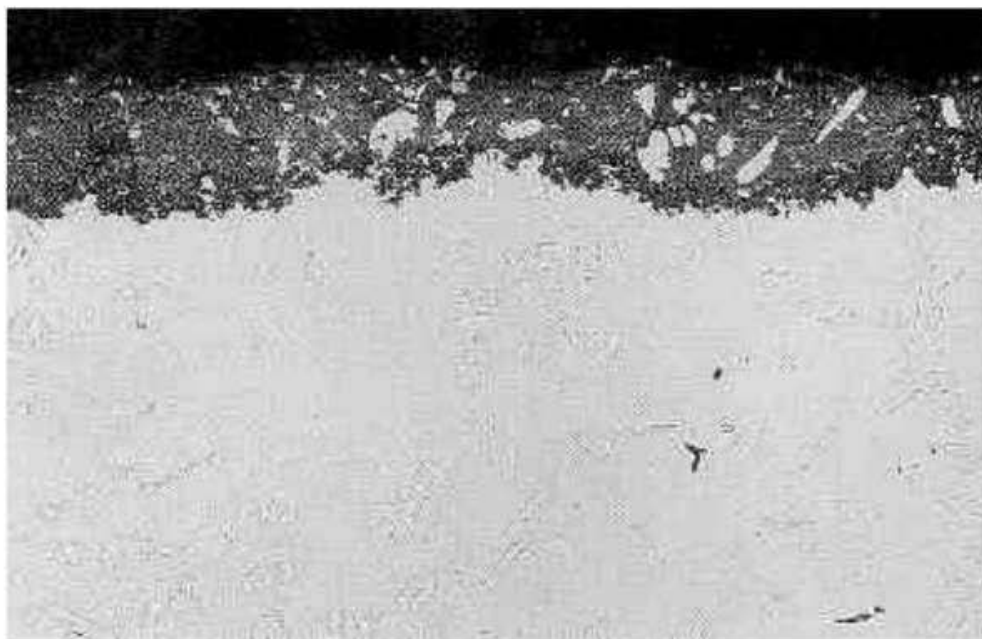
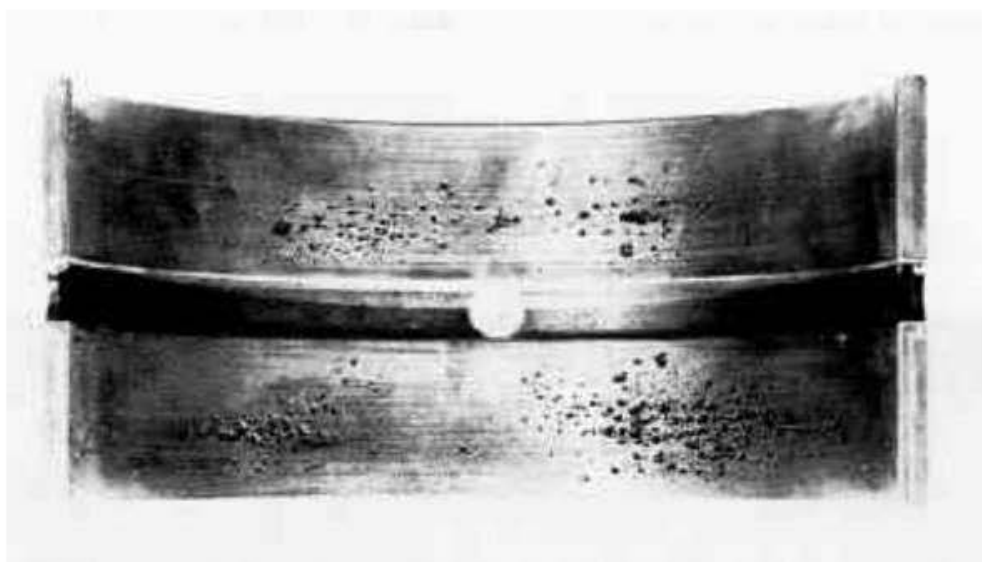


Figure 39 — Tin oxide corrosion due to water in the oil, unetched (material: steel/tin-based white metal)

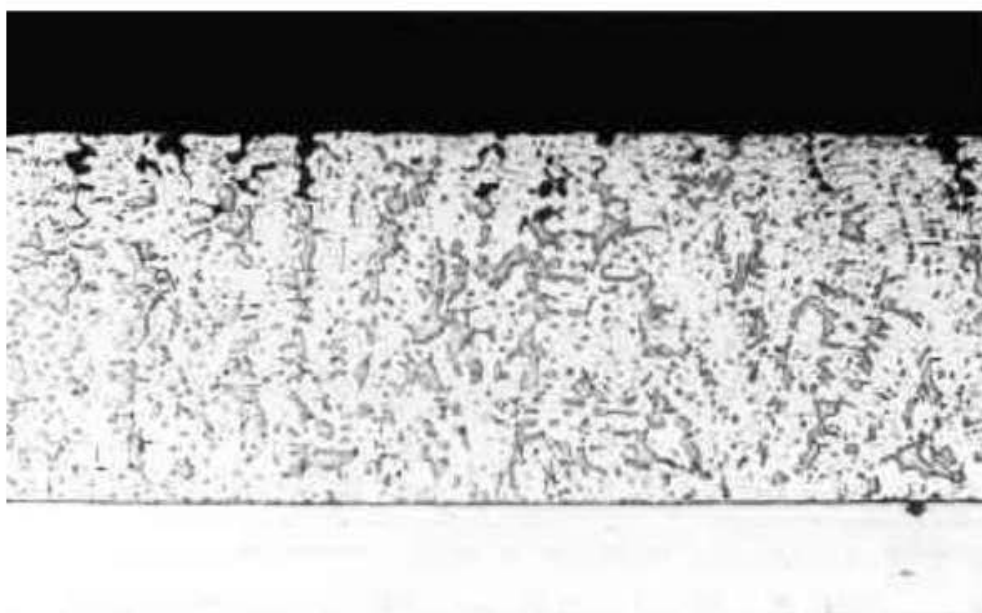


Figure 40 — Corrosion of the surface layer with selective attack on copper and lead in a tin-based material, unetched (material: steel/tin-based white metal)

← direction of shaft rotation



a) structure weakened by corrosion of lead phase after wear of overlay
(material: steel/lead bronze/electroplated overlay)



b) microcut at increased magnification (material: steel/lead bronze/electroplated overlay)

Figure 41



Figure 42 — Deposit of oil carbon on galvanic surface

6.8 Cavitation erosion

6.8.1 General

When the static pressure in a liquid is decreased below the vapour pressure of the liquid at the given temperature, evaporation occurs and vapour bubbles are generated in the liquid. This phenomenon is called cavitation.

With increase of pressure, these bubbles collapse and typically cause very strong local shockwaves in the liquid which damage the bearing surface resulting in cavitation erosion.

6.8.2 Typical damage appearances

Cavitation erosion appearances are characterized by typical worn-out material.

6.8.3 Possible damage causes

For information on cavitation erosion due to faulty design, geometry, material, operation conditions and contamination with foreign fluid elements, see ISO 7146-2. On proven machines, water inclusion is a frequent cause of cavitation erosion.

6.8.4 Typical examples (see Figures 43 and 44)



Figure 43 — Typical cavitation erosion on a thick-walled bearing (material: steel/tin-based white metal)

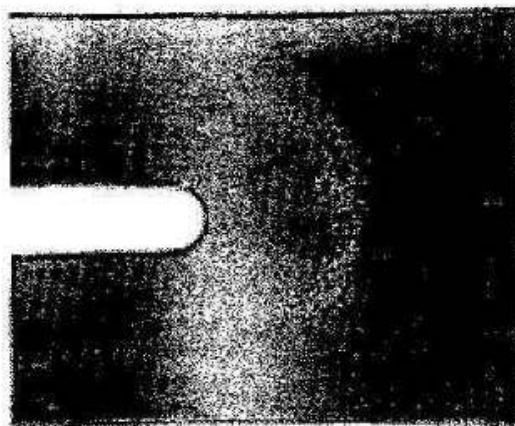


Figure 44 — Typical cavitation erosion on a thin-walled bearing

6.9 Electro-erosion

6.9.1 Typical damage appearance

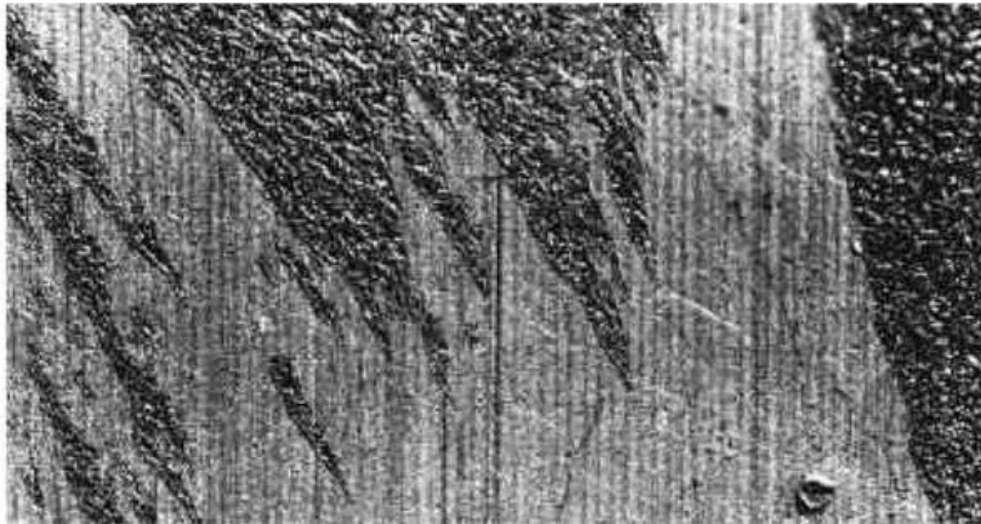
The surfaces of journal and bearing show small craters.

6.9.2 Possible damage causes

Magnetic fields and electrostatic charges can give rise to a potential difference between journal and bearing resulting in current flow.

Insufficient earthing (grounding) or improper insulation in operation or during maintenance, e.g. welding work on the machine, can be a contributory factor.

6.9.3 Typical examples (see Figures 45 to 47)



**Figure 45 — Surface of a plain bearing attacked by electro-erosion
(material: steel/lead bronze/electroplated overlay)**

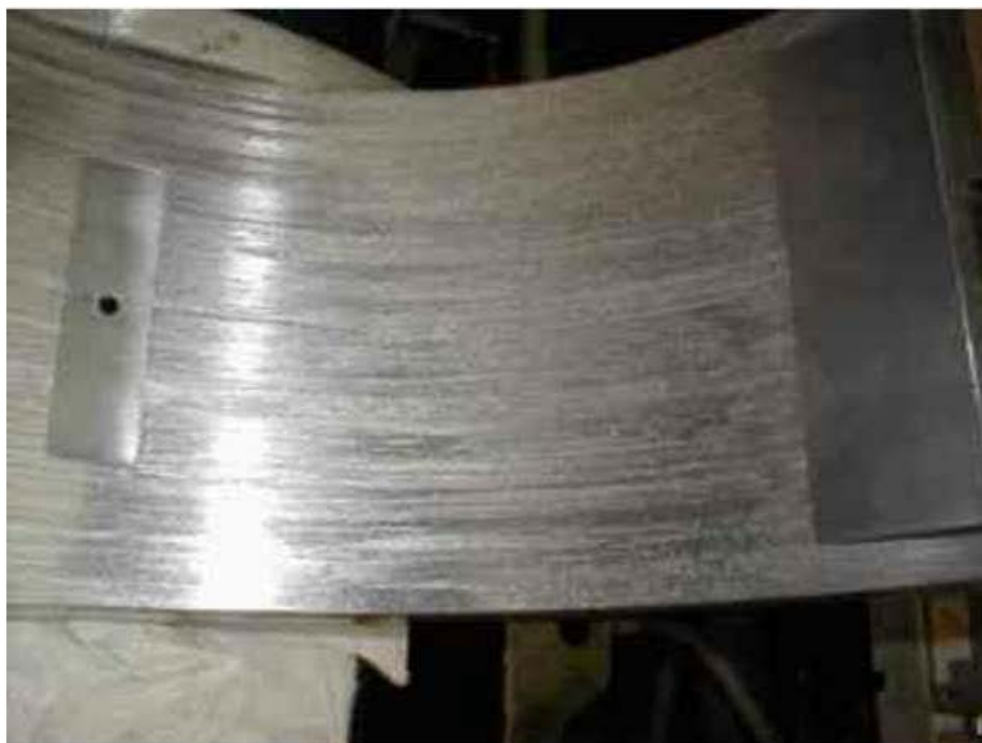


Figure 46 — Formation of electric arc craters

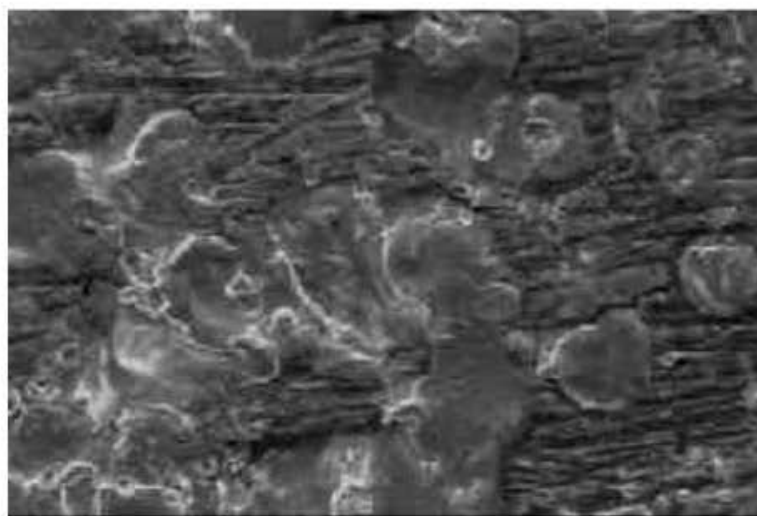


Figure 47 — Electric arc craters at increased magnification (material: tin-based white metal)

6.10 Hydrogen diffusion

6.10.1 Typical damage appearances

For thick-walled bearings: loss of bond between white metal and steel. White metal forms typical blisters (see Figure 48).

For electroplated layers: formation of pores with typical blisters on the layer surface (see Figure 49).

The hydrogen diffusion develops usually over a long time and is accelerated by temperature. These appearances occur either on operation or on spare part bearings after long storage time.

6.10.2 Possible damage cause

Missing additional heat treatment for hydrogen reduction on the steel backing or the electroplated layer. This additional heat treatment is recommended for steel backing thickness above approx. 60 mm.

6.10.3 Typical examples (see Figures 48 and 49)

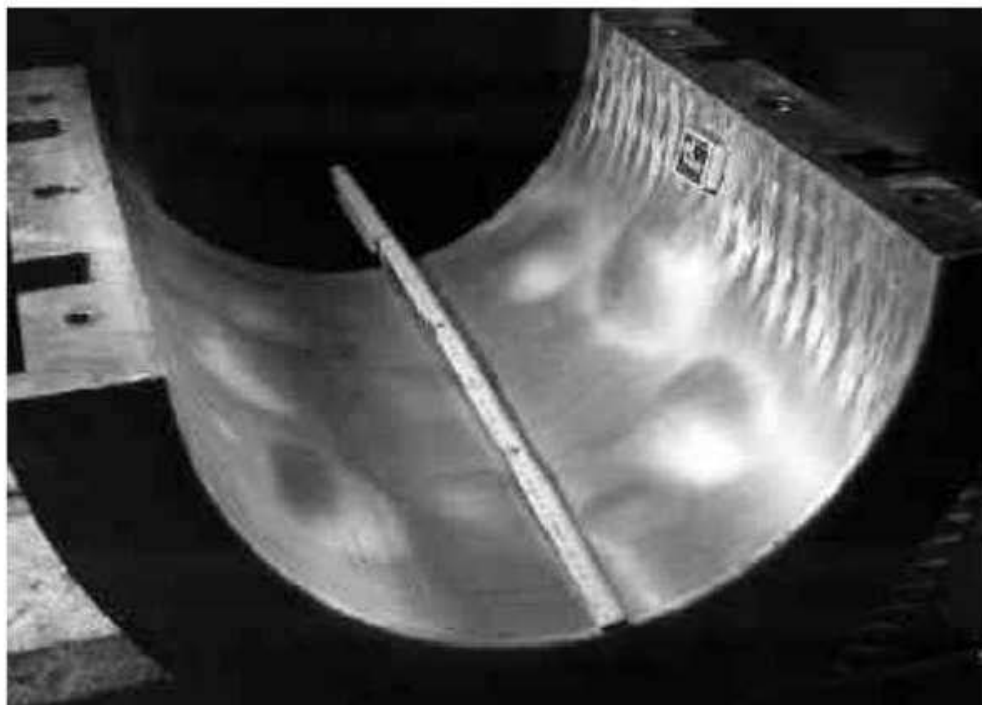
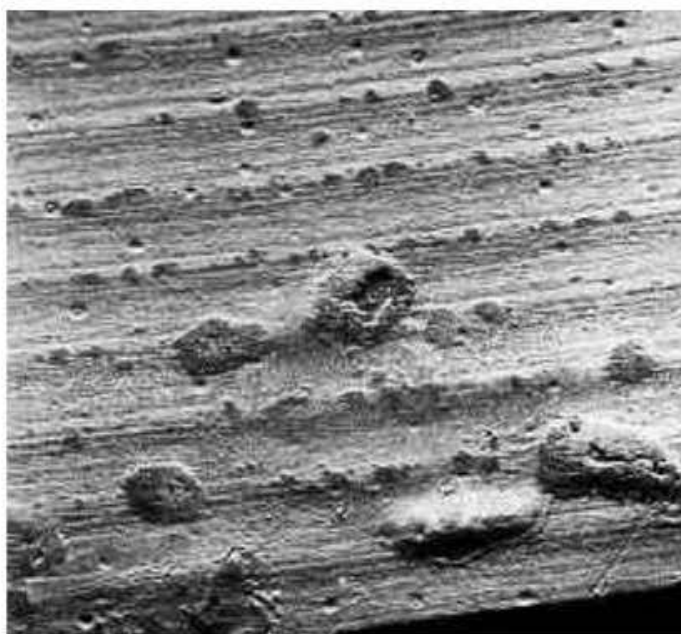


Figure 48 — Layer with loss of bond and formation of typical blisters, arising from hydrogen inclusion in the steel (material: steel/tin-based white metal)

direction of shaft rotation →



**Figure 49 — Hydrogen inclusion arising from electroplating — small pores and larger blisters, partially perforated during running
(material: steel/lead bronze/electroplated overlay at increased magnification)**

6.11 Bond failure

6.11.1 Typical damage appearances

Loss of bond: completely detached material in larger areas with clearly defined borders.

6.11.2 Possible damage causes

Faulty procedure during manufacturing process, e.g. missing heat treatment, insufficient cleaning, tinning, process temperatures.

6.11.3 Typical example (see Figure 50)



**Figure 50 — Loss of white metal showing a break with clearly defined borders
(material: steel/tin-based white metal)**

7 Damage to the bearing back

7.1 General

Sometimes there are damage appearances also on the bearing back or on joint faces. Often there is an interrelationship between the damage to the bearing back and damage to the inside of the bearing.

Damage to the bearing back is discussed for the following damage characterizations: "dynamic overload", "wear by friction" and "contamination with particles".

7.2 Dynamic overload on the bearing back

7.2.1 Typical damage appearance

Frictional corrosion.

Fatigue tracks (see Figure 51).

7.2.2 Possible damage causes

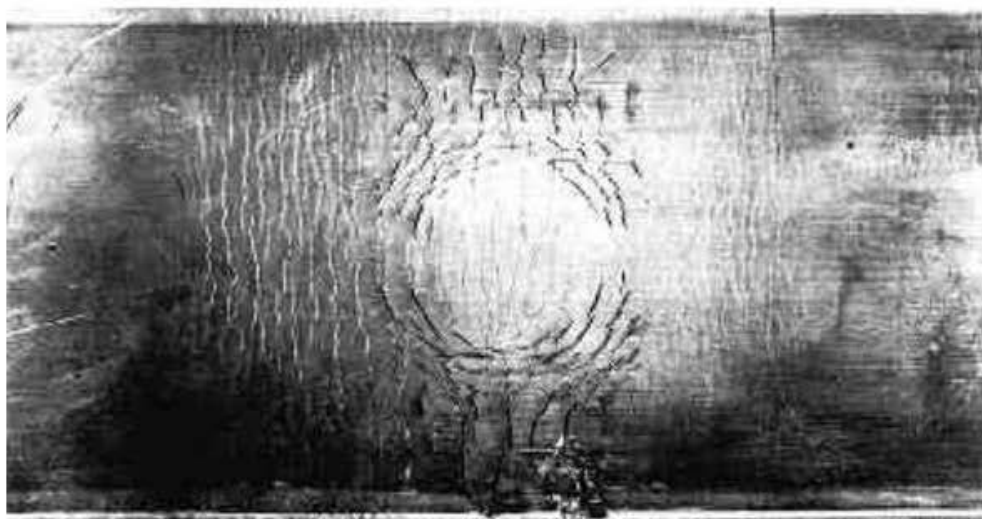
The acting dynamic load can be increased by local influences such as insufficient fit or excessive deformation of the housing. In this case, the damage appearance "frictional corrosion" on the bearing back or on the joint face becomes visible.

If the bearing is not sufficiently supported (oil grooves on the bearing back), a local dynamic overload can also occur (see Figure 51).

7.2.3 Typical examples (see Figure 51)



a) bearing back with appearance of oil groove and hole in the housing (material: steel)



NOTE The black cracks were produced during operation and contain dirty oil. The pale cracks at the sides were produced by bending the bearing open.

b) bearing surface

Figure 51 — Recessed areas (bearing back and corresponding bearing surface) — Insufficient support locally of the bearing in relation to the load

7.3 Wear by friction on the bearing back

7.3.1 Typical damage appearances

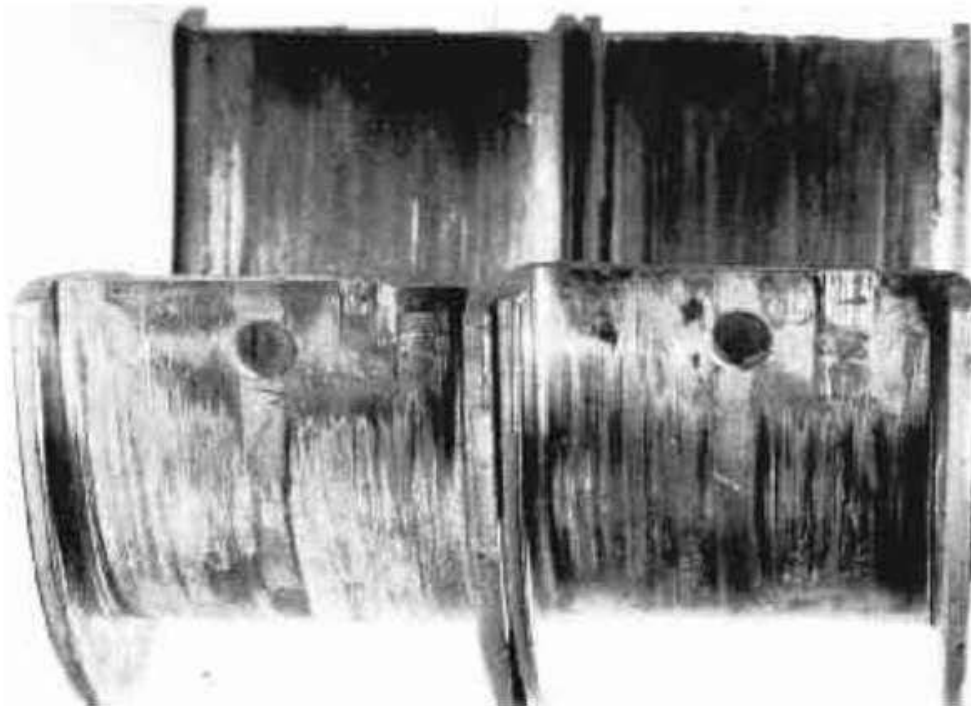
Scoring.

Worn metal.

7.3.2 Possible damage causes

Cumulative small movements of the bearing relative to the housing occurring in the circumferential direction, resulting from excessive elastic deformation of the bearing housing, non-uniform support in the circumferential or axial direction, relaxation of stress in the interference fit, fracture, stretching or insufficient tightening of the bolts etc. In some cases, the bearing movement may be considerable.

7.3.3 Typical examples (see Figures 52 to 54)



NOTE The locating nicks have been flattened towards the bearing surface.

**Figure 52 — Circumferential scoring on the bearing back resulting from slippage
(material: steel/lead bronze/electroplated overlay)**



Figure 53 — Fracture of the steel backing (commencing at the top in an axial direction within an area exhibiting pronounced signs of movement, progressing circumferentially and finally deviating towards the flange)

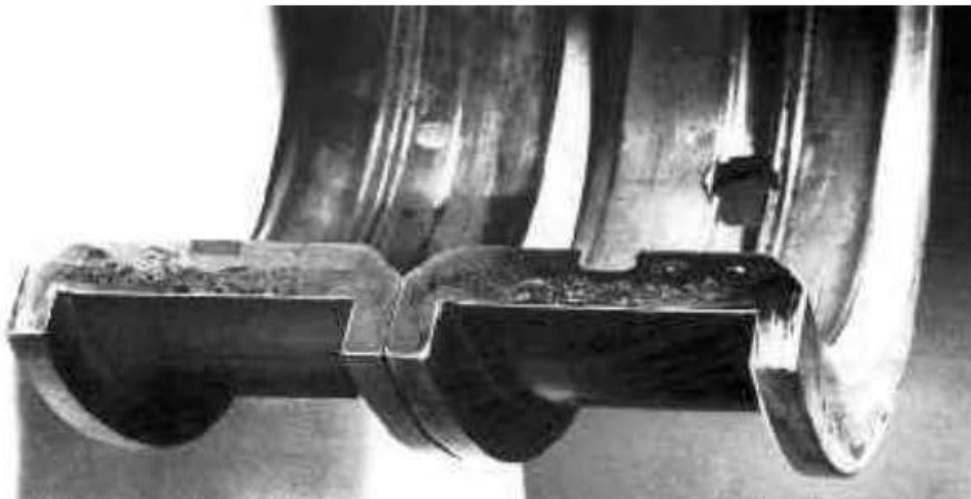


Figure 54 — Pitting and transfer of material at the joint faces

7.4 Contamination with particles on the bearing back

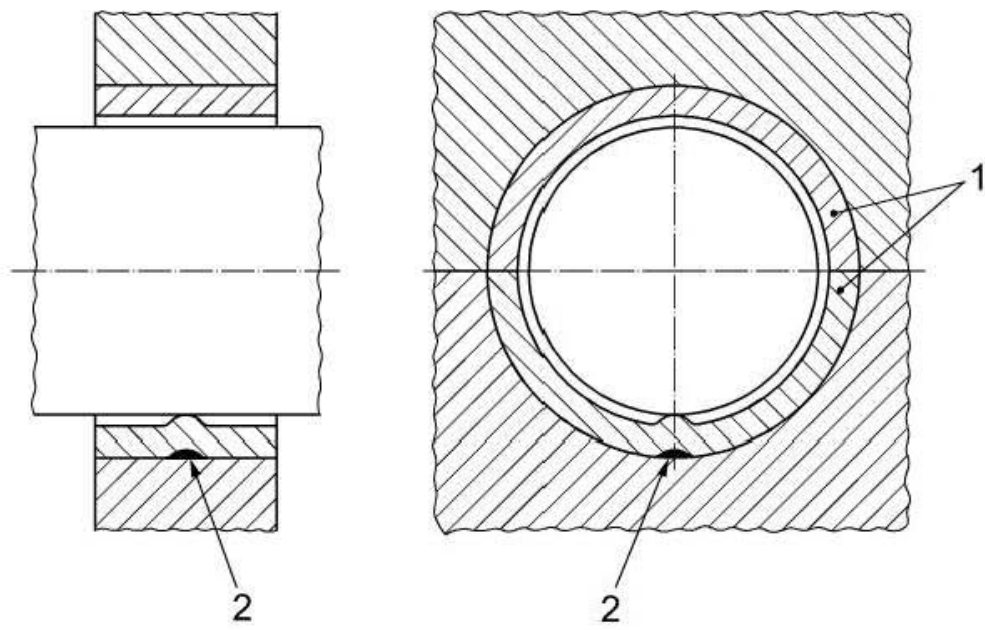
7.4.1 Typical damage appearances

Depositions, embedded particles, scoring, worn metal.

7.4.2 Possible damage cause

Improper assembly.

7.4.3 Typical examples (see Figures 55 and 56)



- Key**
- 1 backing
 - 2 foreign particle

Figure 55 — Schematic diagram of a foreign particle trapped behind a bearing and the resulting raised area



- a) indent on bearing back left by particle trapped between bearing and housing
(material: steel/lead bronze/electroplated overlay)
- b) corresponding worn metal raised area of bearing bore
(material: steel/lead bronze/electroplated overlay)

Figure 56

8 Special position of damage appearances

Damage to the lining is usually concentrated in the area closest to the journal. In a bearing assembly of ideal configuration, the location of this area is directly related to the direction of loading [see Figure 57 a)].

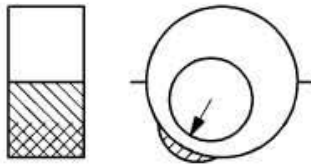
In practice, other areas may also show wear or fatigue damage. This indicates deviation either of the geometry or of the effective loading direction [see Figure 57 b), (1)].

Characteristics

The unexpected shape or position of the damage appearance.

Causes

Incorrect initial geometry of the bearing assembly, distortion by the load, by incorrect assembly or location of backings, etc., or as a result of unpredictable loading.



a) normal

Characteristics

Normal wear across full width (see Figure 16)

Characteristics (1)

Only at one side

Causes

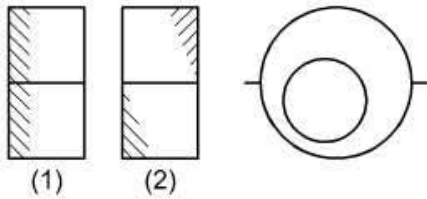
Tapered shaft, bearing or housing, or bent shaft with rotating load

Characteristics (2)

At diagonally opposite sides

Causes

Angular misalignment between bearing and shaft (including misaligned housing, bent connecting rod, etc.)



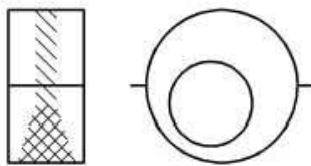
b) edge

Characteristics

Around the centre

Causes

Hour-glass bearing or housing, barrel-shaped shaft, possibly associated with transient overheating or oil starvation



c) central

Characteristics (1)

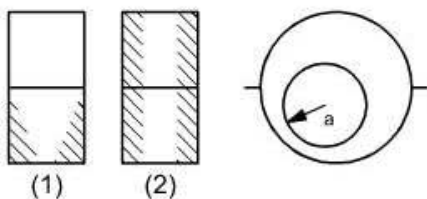
Unidirectional (with unidirectional load)

Characteristics (2)

All around edges (with rotating load)

Causes (1) and (2)

Barrel-shaped bearing or housing, hour-glass shape of shaft, bent shaft or excessive shaft fillet radii



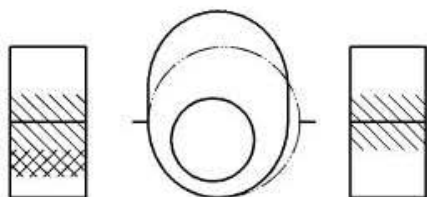
d) both edges

Characteristics

Both adjacent bearings; unexplained by normal loads

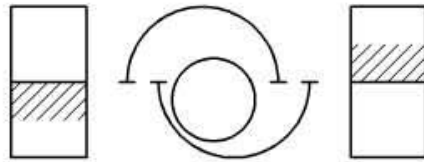
Causes

Distorted bearing or bearing housing (possibly due to load)



e) near joint face (both)

Figure 57 (continued)



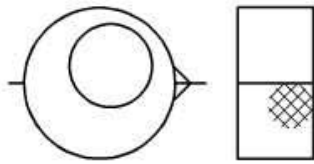
f) near joint face (single)

Characteristics

One bearing near each joint face

Causes

Misplaced bearing cap



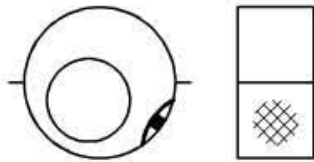
g) small area near joint face

Characteristics

Adjacent to lug

Causes

Locating device not fitting in locating slot



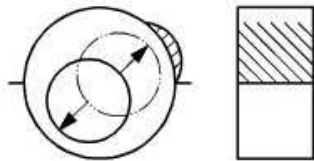
h) high spot

Characteristics

Local area not due to load

Causes

Particle, fretting debris or carbonized oil between bearing back and housing (see Figure 54)



i) unexpected area

Characteristics

Away from normal load

Causes

Unknown additional load, elastic/plastic distortion

Figure 57 — Special appearances of wear or fatigue

Annex A (informative)

Example of use of Table 1

The numbers refer to the labels in Table A.1.

One of the damage appearances visible on the bearing, 1, is material relief, 2, marked as 2a, 2b, and 2c on Table A.1. If only this damage appearance is observed, cells 2a, 2b, and 2c indicate the possible damage characterizations: dynamic overload, 3; hydrogen diffusion, 4; and bond failure, 5. In most cases, the number of relevant damage characterizations can be reduced by further investigations.

If the steel backing of the damaged bearing is already several years old, hydrogen diffusion can be excluded.

The probability of reducing the number of possibilities to only one damage characterization is higher if more than one damage appearance is visible. The example shows in addition to material relief, 2, the damage appearance fatigue cracks, 6, and possibly, on the bearing back, frictional corrosion, 7. All three possible damage appearances corresponding to the damage characterization dynamic overload are detected. Therefore, there is a high probability that the damage characterization is dynamic overload, and a cause should be sought.

What happened in the machine to produce dynamic overload?

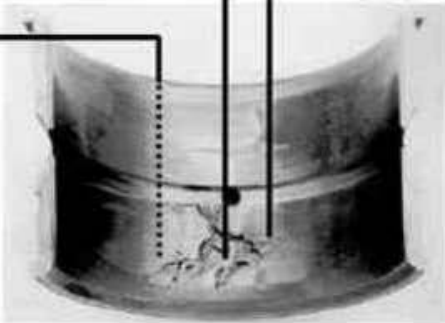
Were there broken parts and/or was mass eccentricity generated?

Did changed operating conditions result in any (higher) impact loads?

Continuation of operation with a damaged bearing increasingly affects hydrodynamic lubrication. Mixed friction increases more and more, 8, and secondary damage characterizations wear, 9, and overheating, 10, occur.

On the latest stage, the liner metal melts out, 11, and corresponds to the damage characterization insufficient lubrication, 12. Damage progress ends in most cases with the secondary damage characterization insufficient lubrication. In such an extreme late stage of damage progress, when no damage appearances beside completely molten metal are visible, an identification of the primary damage characterization is nearly impossible. Fortunately, in most cases, several damage appearances are visible and lead to the relevant damage characterization. To find the real cause, expert knowledge is necessary and cannot be replaced by this International Standard. This International Standard only can give a uniform working basis in order to avoid misunderstanding and misinterpretation.

Table A.1 — Example of interaction of damage appearance and damage characterization

Damage appearance											Damage characteristics	Sub-clause							
Depositions	Creep deformation	Deformations due to temperature cycles	Thermal cracks	Fatigue cracks	Material relief (loss of bond)	Frictional corrosion	Melting out, scoring	Polishing, scoring	Trace of mixed lubrication	Partial wear	Blue, black color	Corrosion	Fluid erosion	Embedded particles, particle migration tracks, formation of wire wool	Electric arc craters	Cavitation erosion appearance: material worn out		1	
x	x	x															Static overload	6.2	
				6													Dynamic overload ¹⁾	6.3	
																	Dynamic overload ²⁾	7.2	
																	Wear by friction ¹⁾	6.4	
																	Wear by friction ²⁾	7.3	
x	x	x	x														Overheating	6.5	
																	Insufficient lubrication (starvation)	6.6	
x																	Contamination (Particles, Chemicals) ¹⁾	6.7	
x																	Contamination (Particles, Chemicals) ²⁾	7.4	
																	Cavitation erosion	6.8 and ISO7146-2	
																	Electro erosion	6.9	
																	Hydrogen diffusion	6.10	
																	Bond failure	6.11	
1) Damage on the sliding surface																			
2) Damage on the bearing back																			